

Property of
Sensata Technologies

ZONE	REV.	REVISION DESCRIPTION	ECN NO.	DATE
B6	P	REMOVED 10.12 MIN DIMENSION & "WITH EXCEPTION TO THE EPOXY AT THE BUS BAR TERMINAL. (SEE FRONT VIEW AT B6)" FROM NOTE 1: D.P.	ECO-063492	30-MAR-2011

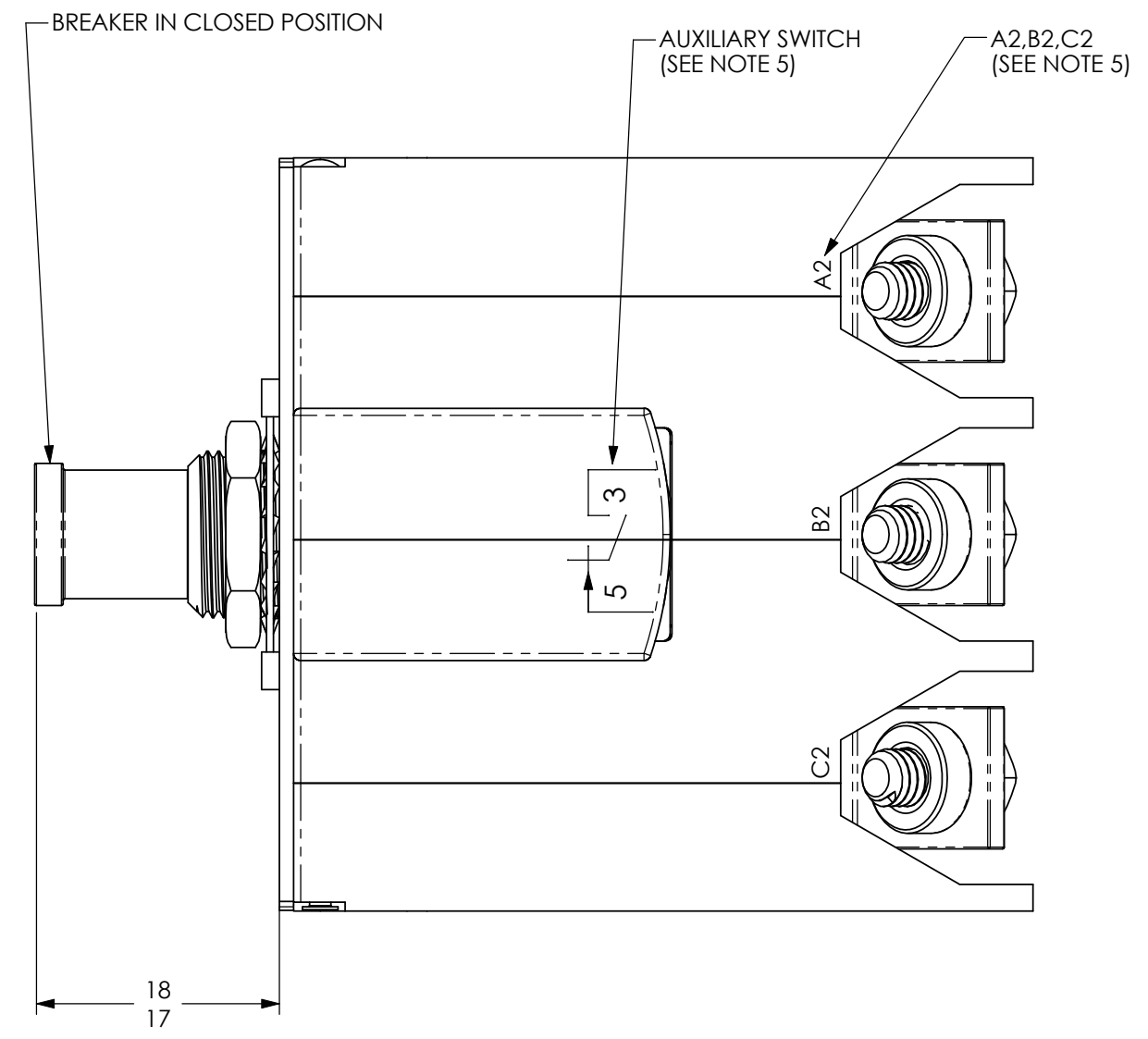
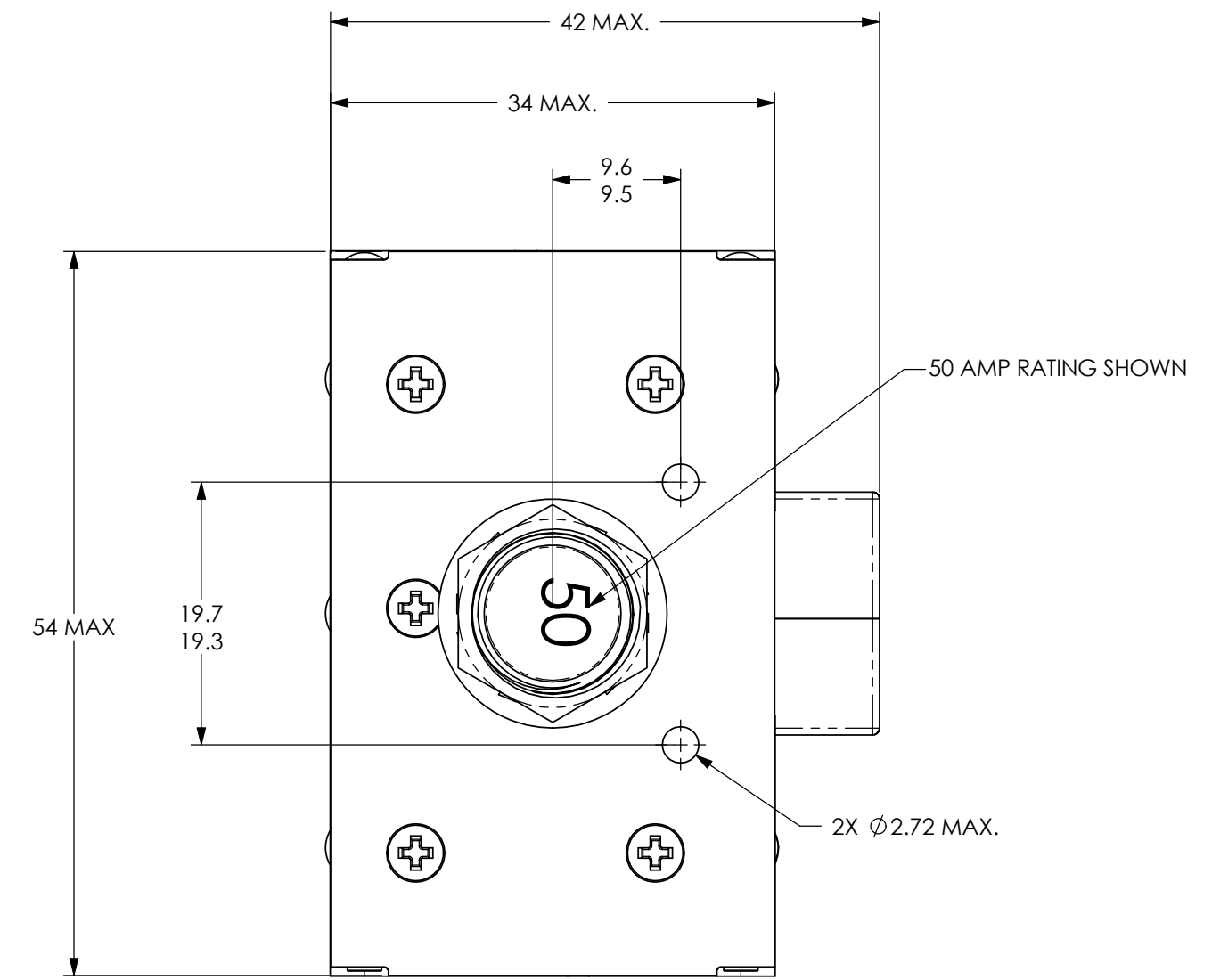
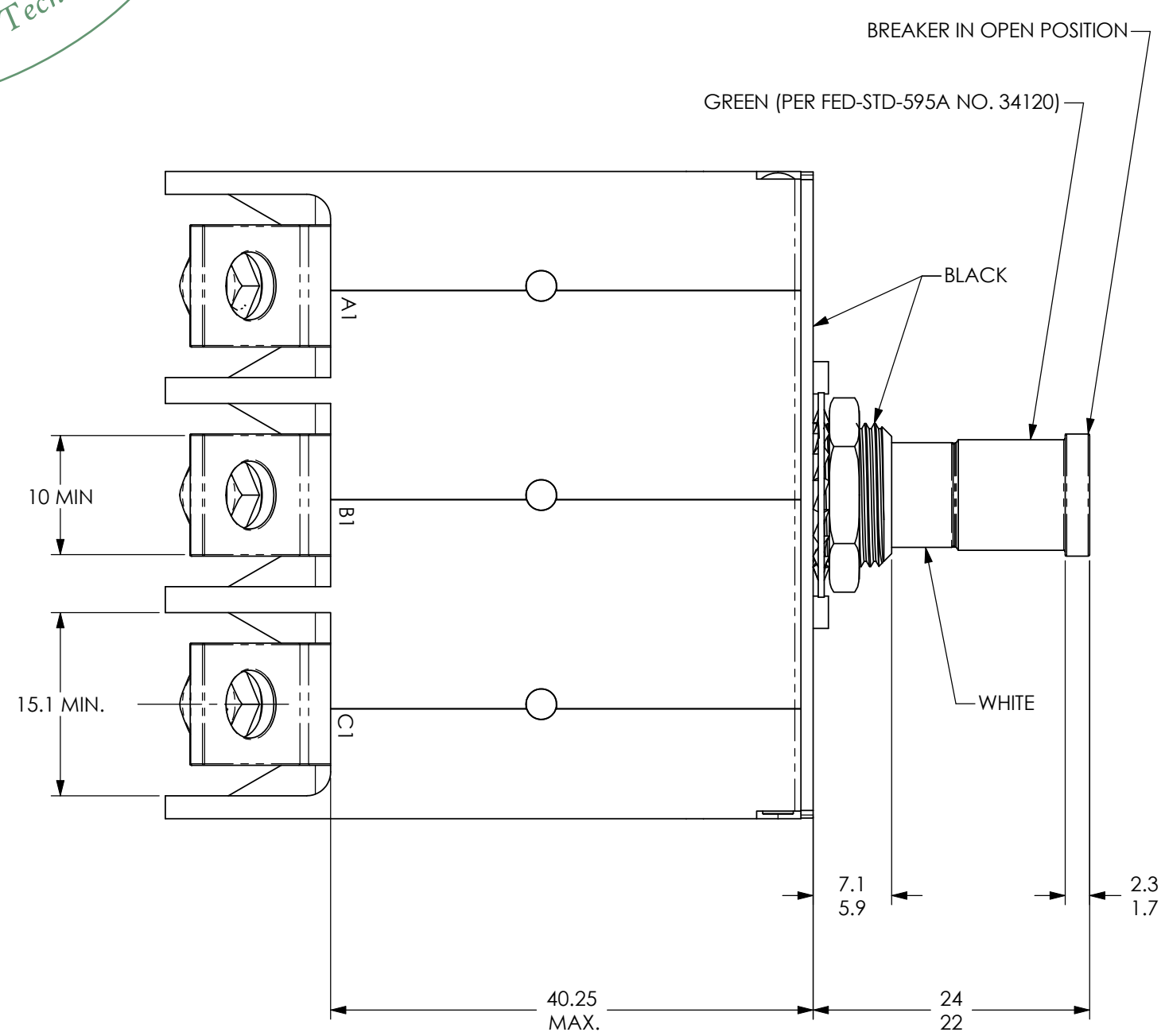

- NOTES
- EPOXY SURFACES ARE NON-DIMENSIONED. ENVELOPE DIMENSIONS DO NOT APPLY TO THESE PROJECTED EPOXY SURFACES.
 - TERMINAL AND MOUNTING HARDWARE MAY BE PACKAGED RATHER THAN INSTALLED.
 - COUNTRY OF ORIGIN IS SHOWN FOR ILLUSTRATION PURPOSES ONLY. COUNTRY OF ORIGIN TO BE IDENTIFIED AS REQUIRED.
 - DATE CODE PER 10588-285.
 - MARK IN APPROXIMATE POSITION SHOWN IN BLACK INK PER 12506-70.
 - VOLUME = 2.5580 CUBIC INCHES.
 - RECOMMENDED PIN CONTACT: GAUGE 20 PER EN3155-016M2018 OR EQUIVALENT.

PERFORMANCE CHARACTERISTICS

DETAIL PERFORMANCE PER prEN3662-001 AND prEN3662-006.

VIBRATION	CURVE 'J' OF EUROCAE ED-14B, 3 G'S, 2000 HZ
MECHANICAL SHOCK	50 G'S
CORROSION	SALT SPRAY 48 HOURS
HUMIDITY	48 HOURS

ENDURANCE:

SINGLE * OR THREE PHASE CALIBRATION:	115 VAC MECHANICAL		360-800 HZ INDUCTIVE NO LOAD		2500 CYCLES 5000 CYCLES	
	MIN. ULT. TRIP	MAX. ULT. TRIP	200% (SEC.)	500% (SEC.)	1000% (SEC.)	
+23 °C (+73 °F)	110% RATING	145% RATING	3 POLES / 1 POLE	3 POLES / 1 POLE	3 POLES / 1 POLE	
+70 °C (+158 °F)	105% RATING	145% RATING	2-20 / 2-22	0.15-4.0 / 0.15-5.2	0.05-1.0 / 0.06-1.3	
+90 °C (+194 °F)	100% RATING	145% RATING	≥ 1.5 / ≥ 1.5	0.15-4.0 / 0.15-5.2	0.05-1.0 / 0.06-1.3	
-55 °C (-67 °F)	110% RATING	165% RATING	≤ 60 / ≤ 110	0.15-4.0 / 0.15-5.2	0.05-1.0 / 0.06-1.3	

SHORT CIRCUIT RESISTANCE: 20 AMP THRU 50 AMP 115 VAC, 400 HZ 2000 AMPS RMS

OPERATIONAL FORCES:
PULL OUT 5 - 45 N (1.1 - 10.1 LBS.)
RESET 20 - 80 N (4.5 - 18 LBS.)

OPERATING ALTITUDE: 15,000 M (49,200 FT.)
WEIGHT INCLUDING CONNECTION HARDWARE: 185.0 GRAMS (0.386 LBS.) MAX.
140.0 GRAMS (0.287 LBS.) NOMINAL

VOLTAGE DROP:

20 AMP	0.150 VOLTS MAX.
25 AMP	0.150 VOLTS MAX.
30 AMP	0.150 VOLTS MAX.
35 AMP	0.150 VOLTS MAX.
50 AMP	0.120 VOLTS MAX.

* SINGLE PHASE MAXIMUM ULTIMATE TRIP VALUES APPLY WITH OTHER TWO PHASES CARRYING 100% OF RATED CURRENT.

SENSATA PART NO.	CUSTOMER PART NO. WITH TERMINAL HARDWARE	CUSTOMER PART NO. WITHOUT TERMINAL HARDWARE
15TC66-20	EN3662-006A20AA	EN3662-006A20AB
15TC66-25	EN3662-006A25AA	EN3662-006A25AB
15TC66-30	EN3662-006A30AA	EN3662-006A30AB
15TC66-35	EN3662-006A35AA	EN3662-006A35AB
15TC66-50	EN3662-006A50AA	EN3662-006A50AB

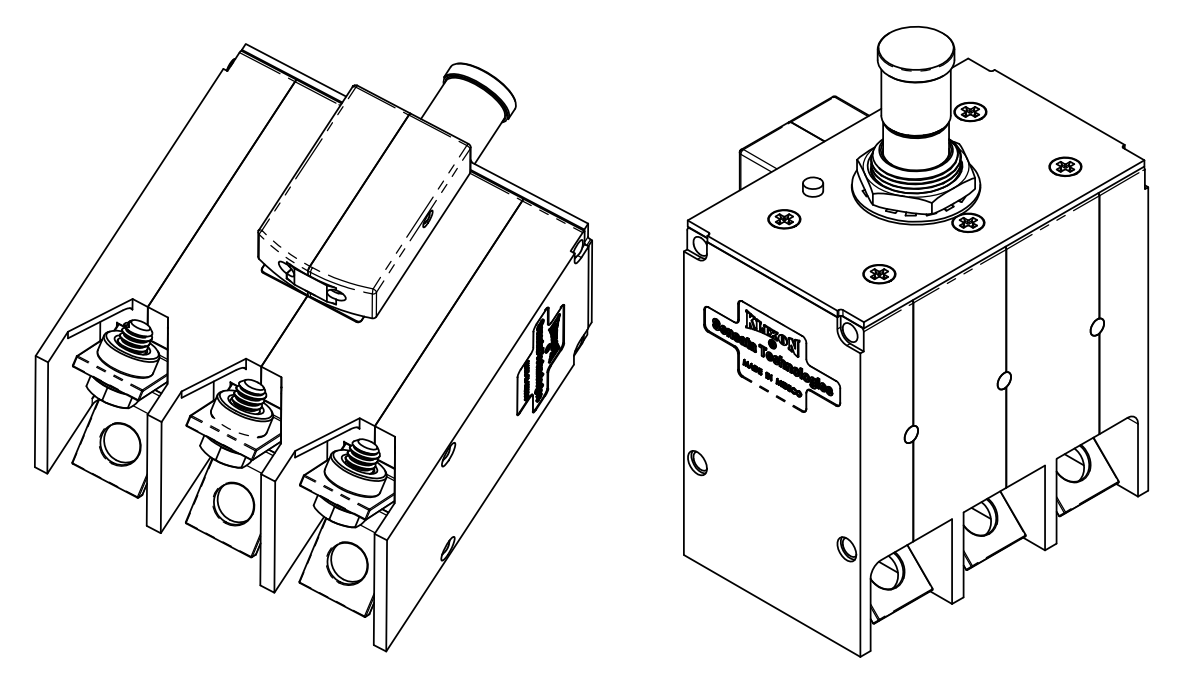
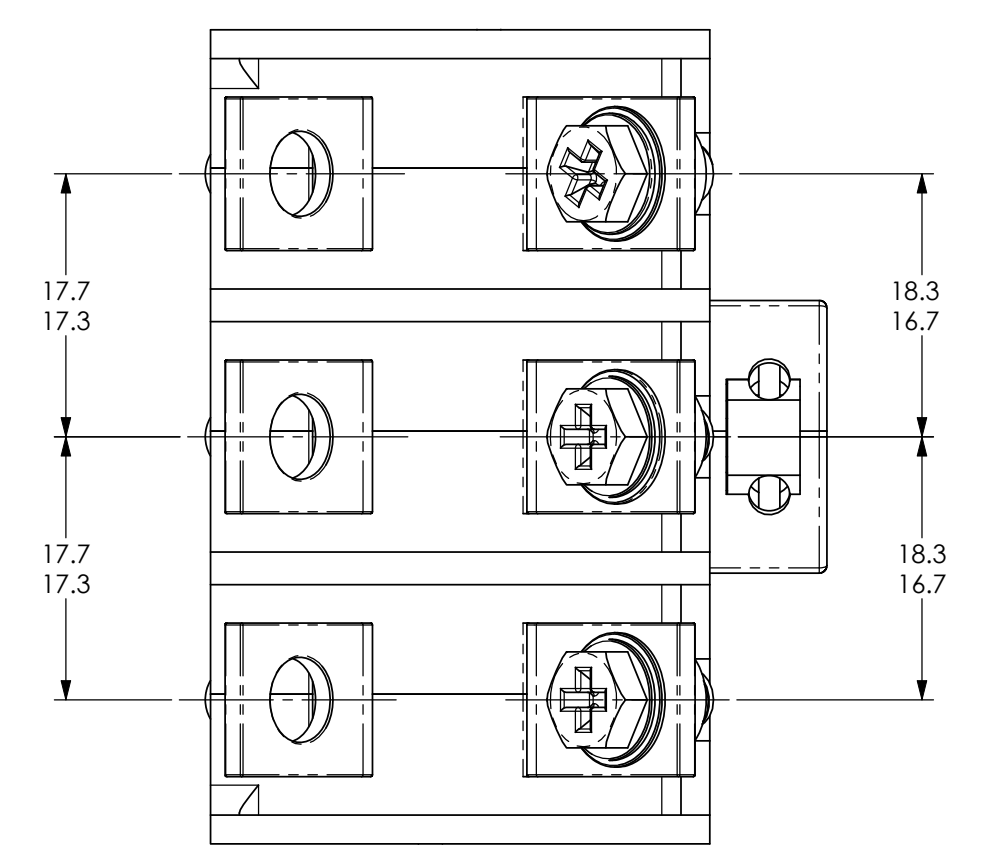
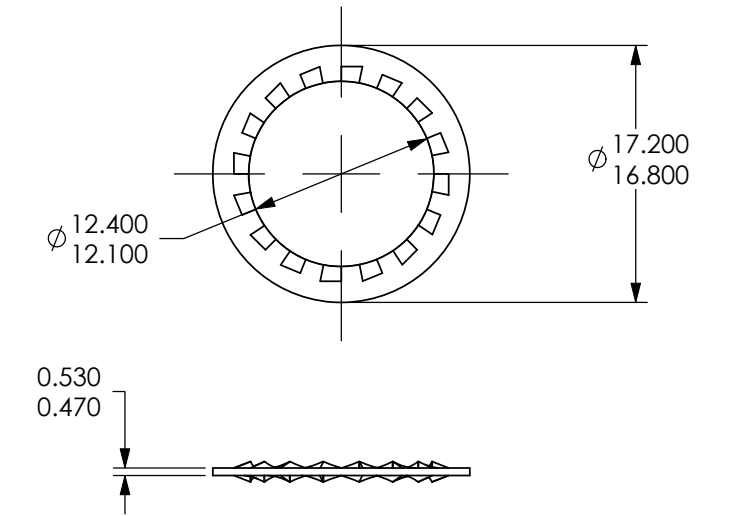
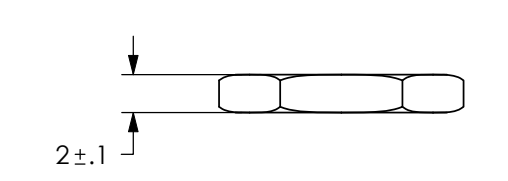
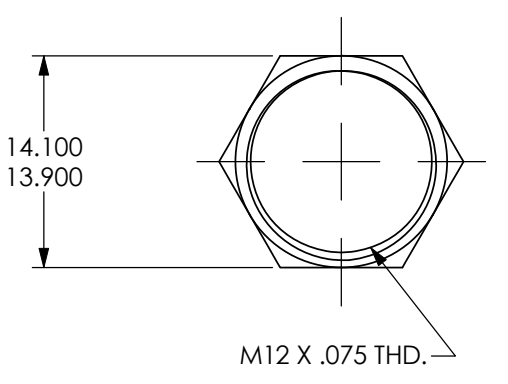
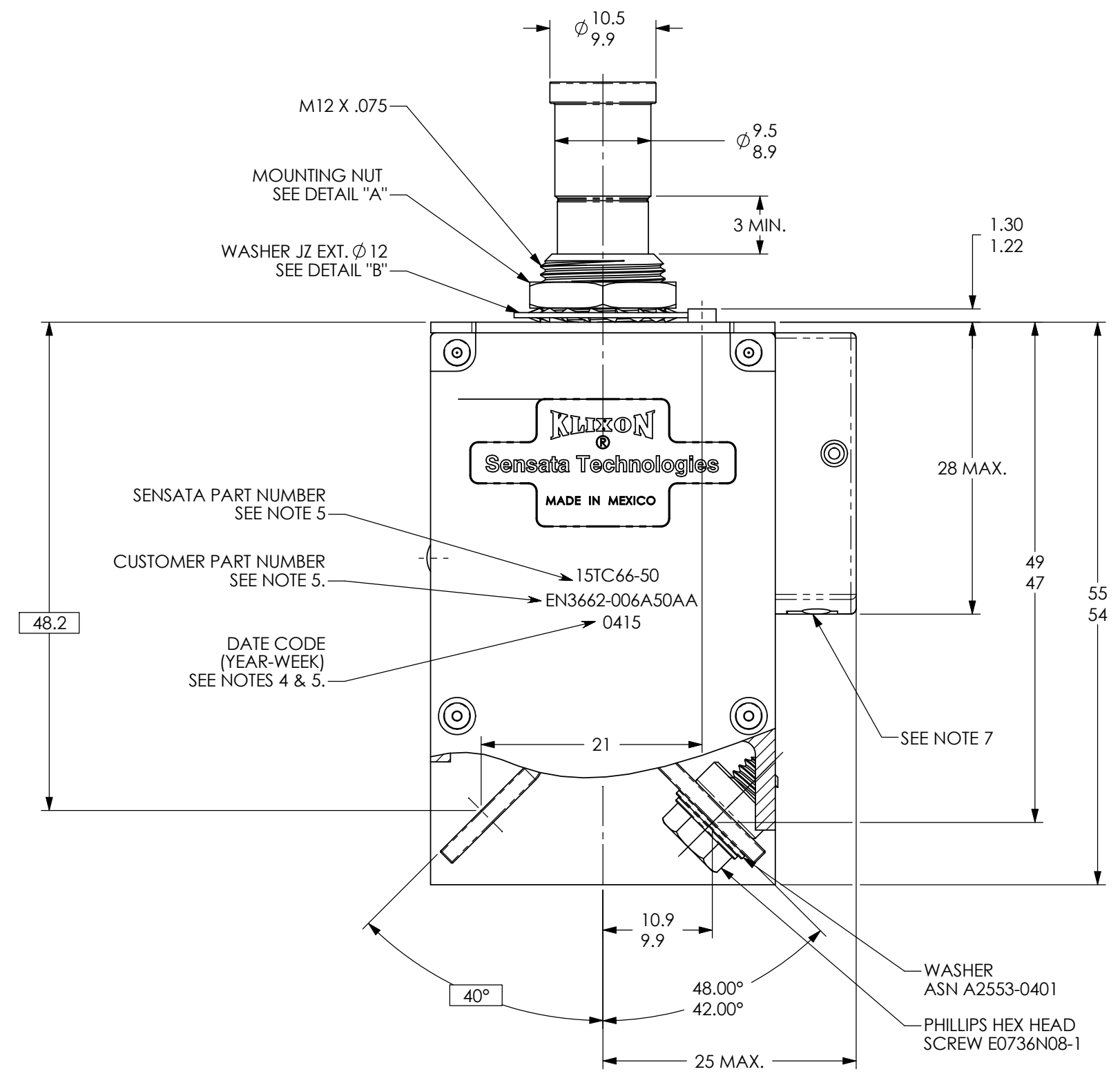

VIEW FOR ILLUSTRATION

FOR REFERENCE ONLY. CHECK LATEST REVISION BEFORE USE. PARTS MADE TO THIS PRINT MUST CONFORM TO E9898 REV. E.		529 PLEASANT STREET P.O. BOX 2964 ATTLEBORO, MA 02703	
DRAWN WILLIAM BENTLEY/DP DATE 28-JUL-2004	SENSATA TECHNOLOGIES PROPRIETARY AND CONFIDENTIAL. NEITHER THIS PRINT NOR THE INFORMATION CONTAINED HEREON IS TO BE USED AGAINST THE INTERESTS OF SENSATA TECHNOLOGIES OR AGAINST THE INTERESTS OF ANY OF ITS AFFILIATED COMPANIES OR WHOLLY OWNED SUBSIDIARIES.		TITLE 15TC CIRCUIT BREAKER BUS BAR TERMINALS PUSH PULL, TRIP FREE ENVELOPE DRAWING
ENGINEER WILLIAM BENTLEY DATE 28-JUL-2004	UNLESS OTHERWISE SPECIFIED DIMENSIONS ARE IN MILLIMETERS TOLERANCES		SCALE DWG NO. REV.
APPROVED R.FERNANDES DATE 28-JUL-2004	DECIMALS X.XX ±.10 X.XXX ±.05	ANGLES X.X° ±1° X.XX° ±.5°	A1 15TC66 P
APPROVED C.REGALADO DATE 28-JUL-2004	DO NOT SCALE DRAWING	THIRD ANGLE PROJECTION	SCALE 2:1 SOLIDWORKS SHEET 1 OF 1

DEVICE: 15TC66 PROJECT: EX3636