

PERFORMANCE SPECIFICATION SHEET

CIRCUIT BREAKERS, MAGNETIC, UNSEALED
TRIP-FREE, SINGLE POLE, AUXILIARY CONTACTS
(0.2 TO 50 AMPERES)

This specification is approved for use by all Departments and Agencies of the Department of Defense.

The requirements for acquiring the product described herein shall consist of this specification sheet and [MIL-PRF-55629](#).

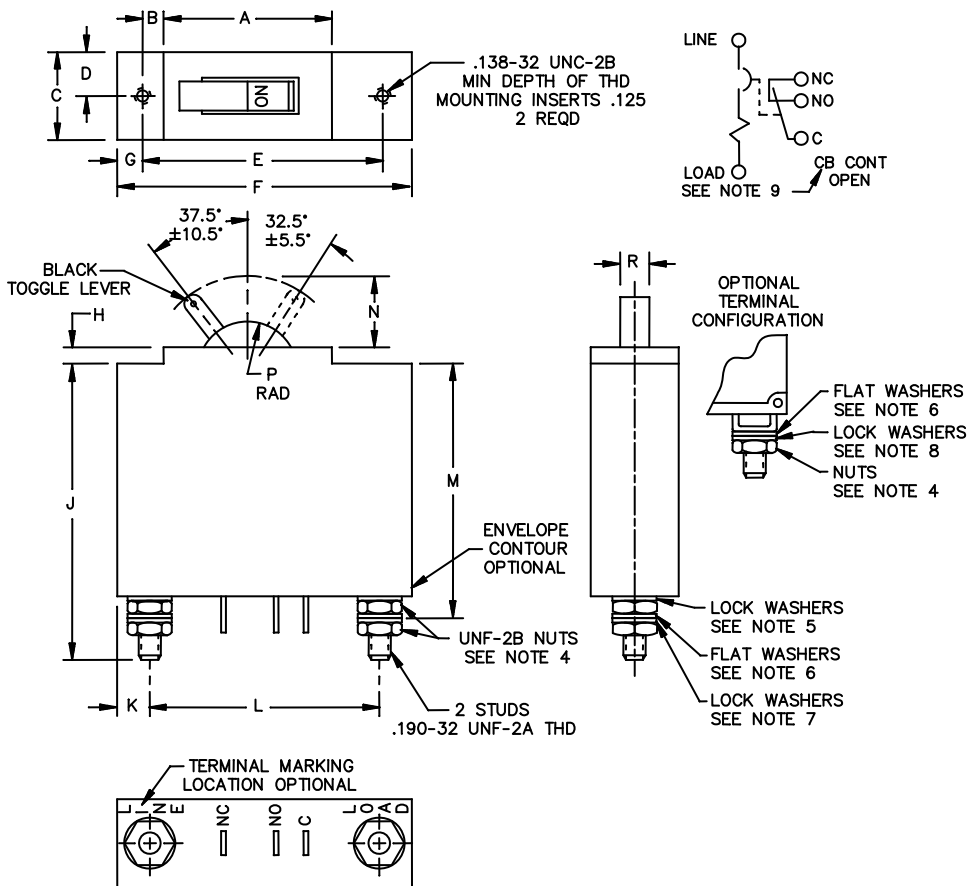

FIGURE 1. Dimensions and configurations (configuration 1).

MIL-PRF-55629/2G

Ltr	Inches		mm	
	Min	Max	Min	Max
A	1.420	1.470	36.07	37.34
B	.149	.211	3.78	5.36
C	.730	.780	18.54	19.81
D	.359	.391	9.12	9.93
E	2.046	2.078	51.97	52.78
F	---	2.530	---	64.26
G	.187	.249	4.75	6.32
H	.109	.171	2.77	4.34
J	---	2.800	---	71.12
K	.249	.311	6.32	7.90
L	1.660	1.960	42.16	49.78
M	---	2.340	---	59.44
N	.519	.699	13.18	17.75
P	---	.427 R	---	10.84 R
R	.230	.270	5.84	6.86

NOTES:

1. Dimensions are in inches.
2. Metric equivalents are given for general information only.
3. Unless otherwise specified, tolerance is ± 0.031 (0.79 mm).
4. Nut-hex: .190 - 32 UNF-2B, .313/.303 across flats, .109 ± 0.010 thick. Material: Brass (ASTM-B121/B121M or equivalent); tin plated (ASTM-B545 or equivalent); or stainless steel, for each terminal.
5. Captive washer nut assembly of brass nut, bronze washer, tin plated; or lockwasher, internal or external tooth, NASM35333-107 or MS35335-88 or equivalent.
6. Washer, flat: .378/.368 O.D., .204/.190 I.D., .032 ± 0.005 thick. Material: Brass (ASTM-B121/B121M or equivalent), tin plated (ASTM-B545 or equivalent), or phosphor bronze, composition (ASTM-B139/B139M or equivalent).
7. Auxiliary contact terminals shall provide for soldered connections and shall be located on the back side of the circuit breaker (same surface as main terminals) otherwise location, style, and design are optional.
8. Lockwasher, Split: NASM35338-138 or equivalent.
9. Physical item marking of the words "LOAD" and "CB CONT OPEN" is optional.

FIGURE 1. Dimensions and configurations (configuration 1) – Continued.

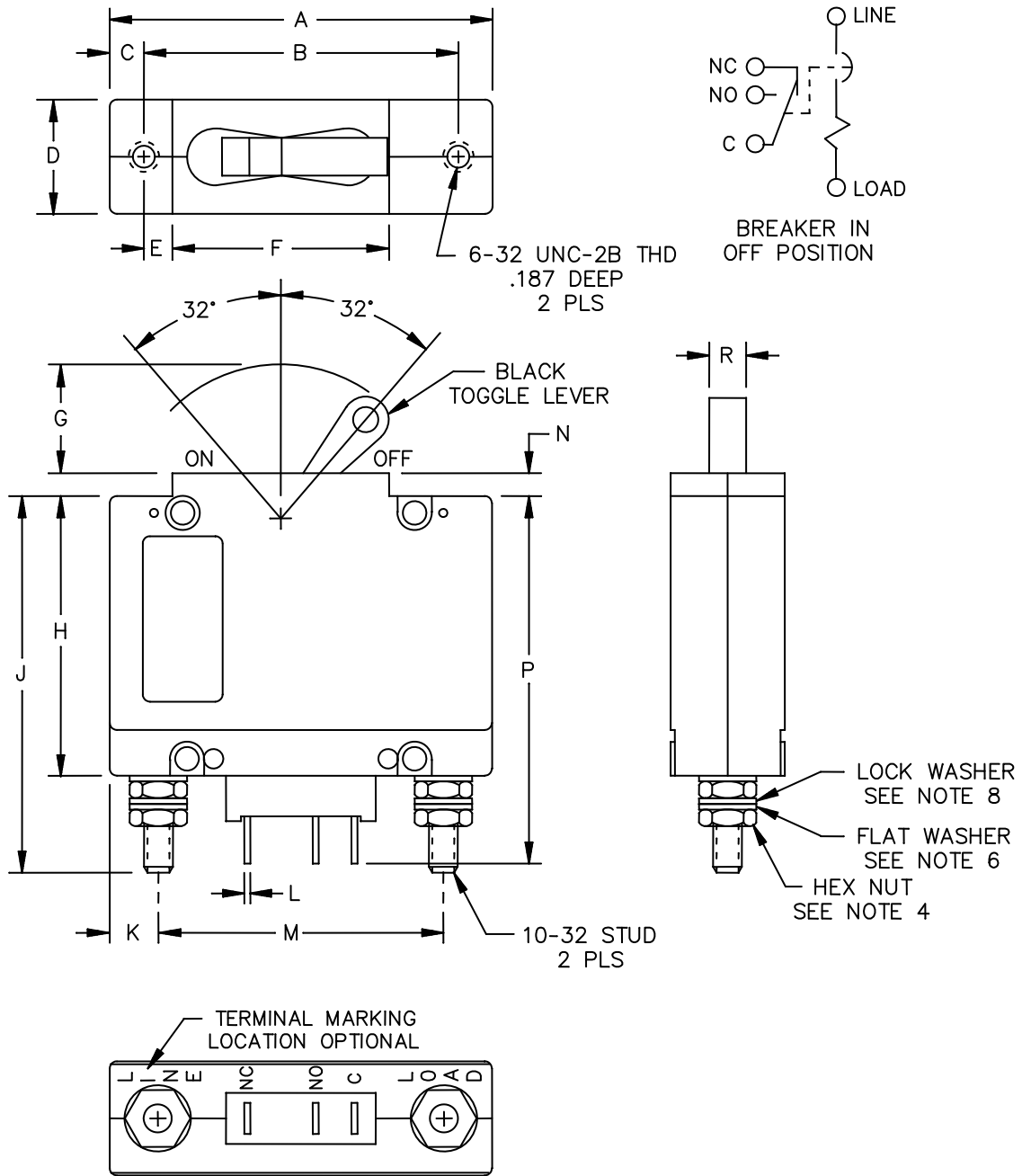

FIGURE 2. Dimensions and configurations (configuration 2).

MIL-PRF-55629/2G

Ltr	Inches		mm	
	Min	Max	Min	Max
A	2.475	2.505	62.87	63.63
B	2.045	2.075	51.94	52.71
C	.205	.235	5.21	5.97
D	---	.750	---	19.05
E	.167	.197	4.24	5.00
F	1.423	1.453	36.14	36.91
G	.535	.565	13.59	14.35
H	1.921	2.081	48.79	52.86
J	---	2.514	---	63.86
K	.266	.296	6.76	7.52
L	.019	.021	0.48	0.53
M	1.925	1.955	48.90	49.66
N	.125	.155	3.18	3.94
P	---	2.438	---	61.93
R	.245	.275	6.22	6.98

NOTES:

1. Dimensions are in inches.
2. Metric equivalents are given for general information only.
3. Unless otherwise specified, tolerance is $\pm .015$ (0.38 mm).
4. Nut-hex: .190 - 32 UNF-2B .313/.303 across flats, .109 \pm .010 thick. Material: Brass (ASTM-B121/B121M or equivalent); tin plated (ASTM-B545 or equivalent); or stainless steel, for each terminal.
5. Captive washer nut assembly of brass nut, bronze washer, tin plated; or lockwasher, internal or external tooth, NASM35333-107 or MS35335-88.
6. Washer, flat: .378/.368 O.D., .204/.190 I.D., .032 \pm .005 thick. Material: Brass (ASTM-B121/B121M or equivalent), tin plated (ASTM-B545 or equivalent), or phosphor bronze, composition (ASTM B139/B139M or equivalent).
7. Auxiliary contact terminals shall provide for soldered connections and shall be located on the back side of the circuit breaker (same surface as main terminals) otherwise location, style and design are optional.
8. Lockwasher, Split: NASM35338-138 or equivalent.
9. Physical item marking of the words "LOAD" and "CB CONT OPEN" is optional.
10. For configuration 2, an "L" has been added to the end of the dash number.

FIGURE 2. Dimensions and configurations (configuration 2) - Continued.

REQUIREMENTS

Dimensions and configuration: See figures 1 and 2.

Current ratings: See tables I and II.

Voltage ratings: See table III through table VIII. 240 V ac breakers are designed also for use at 120 V ac.

High inrush: Applicable to time delays K, L, M, N, P, R, S, and T. Non-time delays H, I, and J are not high inrush delays.

Tripping-time delays: See table III through table VIII.

Terminal and mounting hardware: See figures 1 and 2.

Terminals: See figures 1 and 2.

Auxiliary contact terminals: Contact capacity shall be 10 amperes at 250 volts 60/400 Hz and 2 amperes resistive, 1 ampere inductive to 50 V dc.

Actuator strength: 25 pounds.

Actuator operating force: 4 pounds, maximum.

Terminal strength:

Applied load: 30 pounds.

Applied torque: 22 inch-pounds.

Vibration: Energized current shall be 90 percent for characteristics H, I, and J.

Shock: Energized current shall be 90 percent for characteristics H, I, and J.

Interrupting capacities:

2,000 amperes at 50 V dc.

2,000 amperes at 120 V ac, 60 Hz.

1,500 amperes at 120 V ac, 400 Hz.

1,000 amperes at 240 V ac, 60 and 400 Hz.

Part or Identifying Number (PIN): M55629/2-(dash number from table I).

MIL-PRF-55629/2G

TABLE I. Circuit breaker dash numbers and applicable characteristics (configuration 1).

Dash no.	Current rating (amperes)	Voltage frequency and tripping time delay code letter (see tables III, IV, V and VIII)	Resistance or impedance ohms (max.)	Dash no.	Current rating (amperes)	Voltage frequency and tripping time delay code letter (see tables III, IV, V and VIII)	Resistance or impedance ohms (max.)
001	0.2	A	32	269	0.5	P	12
002	0.2	B	32	270	0.5	R	12
003	0.2	C	34	271	0.5	S	12
004	0.2	D	34	428	0.5	T	6
005	0.2	E	72	150	0.75	A	3
006	0.2	F	72	151	0.75	B	3
007	0.2	G	72	153	0.75	C	3
134	0.2	H	32	154	0.75	D	3
135	0.2	I	34	156	0.75	E	7
136	0.2	J	72	157	0.75	F	7
251	0.2	K	32	158	0.75	G	7
252	0.2	L	32	152	0.75	H	3
253	0.2	M	34	155	0.75	I	3
254	0.2	N	34	159	0.75	J	7
255	0.2	P	72	272	0.75	K	3
256	0.2	R	72	273	0.75	L	3
257	0.2	S	72	274	0.75	M	3
426	0.2	T	34	275	0.75	N	3
137	0.25	A	21	276	0.75	P	7
138	0.25	B	21	277	0.75	R	7
140	0.25	C	23	278	0.75	S	7
141	0.25	D	23	429	0.75	T	3
143	0.25	E	43	015	1.0	A	2
144	0.25	F	43	016	1.0	B	2
145	0.25	G	43	017	1.0	C	2
139	0.25	H	21	018	1.0	D	2
142	0.25	I	23	019	1.0	E	4
146	0.25	J	43	020	1.0	F	4
258	0.25	K	21	021	1.0	G	4
259	0.25	L	21	160	1.0	H	2
260	0.25	M	23	161	1.0	I	2
261	0.25	N	23	162	1.0	J	4
262	0.25	P	43	279	1.0	K	2
263	0.25	R	43	280	1.0	L	2
264	0.25	S	43	281	1.0	M	2
427	0.25	T	23	282	1.0	N	2
008	0.5	A	6	283	1.0	P	4
009	0.5	B	6	284	1.0	R	4
010	0.5	C	6	285	1.0	S	4
011	0.5	D	6	430	1.0	T	2
012	0.5	E	12	163	1.5	A	.9
013	0.5	F	12	164	1.5	B	.9
014	0.5	G	12	166	1.5	C	.9
147	0.5	H	6	167	1.5	D	.9
148	0.5	I	6	169	1.5	E	2
149	0.5	J	12	170	1.5	F	2
265	0.5	K	6	171	1.5	G	2
266	0.5	L	6	165	1.5	H	.9
267	0.5	M	6	168	1.5	I	.9
268	0.5	N	6	172	1.5	J	2

MIL-PRF-55629/2G

TABLE I. Circuit breaker dash numbers and applicable characteristics (configuration 1) - Continued.

Dash no.	Current rating (amperes)	Voltage frequency and tripping time delay code letter (see tables III, IV, V and VIII)	Resistance or impedance ohms (max.)	Dash no.	Current rating (amperes)	Voltage frequency and tripping time delay code letter (see tables III, IV, V and VIII)	Resistance or impedance ohms (max.)
286	1.5	K	.9	035	3.0	G	.5
287	1.5	L	.9	186	3.0	H	.3
288	1.5	M	.9	187	3.0	I	.3
289	1.5	N	.9	188	3.0	J	.5
290	1.5	P	2	307	3.0	K	.3
291	1.5	R	2	308	3.0	L	.3
292	1.5	S	2	309	3.0	M	.3
431	2.0	T	.9	310	3.0	N	.3
022	2.0	A	.5	311	3.0	P	.5
023	2.0	B	.5	312	3.0	R	.5
024	2.0	C	.5	313	3.0	S	.5
025	2.0	D	.5	434	3.0	T	.3
026	2.0	E	.8	189	3.5	A	.15
027	2.0	F	.8	190	3.5	B	.15
028	2.0	G	.8	192	3.5	C	.15
173	2.0	H	.5	193	3.5	D	.15
174	2.0	I	.5	195	3.5	E	.35
175	2.0	J	.8	196	3.5	F	.35
293	2.0	K	.5	197	3.5	G	.35
294	2.0	L	.5	191	3.5	H	.15
295	2.0	M	.5	194	3.5	I	.15
296	2.0	N	.5	198	3.5	J	.35
297	2.0	P	.8	314	3.5	K	.15
298	2.0	R	.8	315	3.5	L	.15
299	2.0	S	.8	316	3.5	M	.15
432	2.0	T	.5	317	3.5	N	.15
176	2.5	A	.35	318	3.5	P	.35
177	2.5	B	.35	319	3.5	R	.35
179	2.5	C	.35	320	3.5	S	.35
180	2.5	D	.35	435	3.5	T	.15
182	2.5	E	.6	036	4.0	A	.1
183	2.5	F	.6	037	4.0	B	.1
184	2.5	G	.6	038	4.0	C	.1
178	2.5	H	.35	039	4.0	D	.1
181	2.5	I	.35	040	4.0	E	.3
185	2.5	J	.6	041	4.0	F	.3
300	2.5	K	.35	042	4.0	G	.3
301	2.5	L	.35	199	4.0	H	.1
302	2.5	M	.35	200	4.0	I	.1
303	2.5	N	.35	201	4.0	J	.3
304	2.5	P	.6	321	4.0	K	.1
305	2.5	R	.6	322	4.0	L	.1
306	2.5	S	.6	323	4.0	M	.1
433	2.5	T	.35	324	4.0	N	.1
029	3.0	A	.3	325	4.0	P	.3
030	3.0	B	.3	326	4.0	R	.3
031	3.0	C	.3	327	4.0	S	.3
032	3.0	D	.3	436	4.0	T	.1
033	3.0	E	.5	043	5.0	A	.08
034	3.0	F	.5	044	5.0	B	.08

MIL-PRF-55629/2G

TABLE I. Circuit breaker dash numbers and applicable characteristics (configuration 1) - Continued.

Dash no.	Current rating (amperes)	Voltage frequency and tripping time delay code letter (see tables III, IV, V and VIII)	Resistance or impedance ohms (max.)	Dash no.	Current rating (amperes)	Voltage frequency and tripping time delay code letter (see tables III, IV, V and VIII)	Resistance or impedance ohms (max.)
045	5.0	C	.08	348	7.0	S	.07
046	5.0	D	.08	449	7.0	T	.04
047	5.0	E	.15	064	8.0	A	.03
048	5.0	F	.15	065	8.0	B	.03
049	5.0	G	.15	066	8.0	C	.03
202	5.0	H	.08	067	8.0	D	.03
203	5.0	I	.08	068	8.0	E	.06
204	5.0	J	.15	069	8.0	F	.06
328	5.0	K	.08	070	8.0	G	.06
329	5.0	L	.08	211	8.0	H	.03
330	5.0	M	.08	212	8.0	I	.03
331	5.0	N	.08	213	8.0	J	.06
332	5.0	P	.15	349	8.0	K	.03
333	5.0	R	.15	350	8.0	L	.03
334	5.0	S	.15	351	8.0	M	.03
437	5.0	T	.08	352	8.0	N	.03
050	6.0	A	.06	353	8.0	P	.06
051	6.0	B	.06	354	8.0	R	.06
052	6.0	C	.06	355	8.0	S	.06
053	6.0	D	.06	440	8.0	T	.03
054	6.0	E	.08	071	9.0	A	.018
055	6.0	F	.08	072	9.0	B	.018
056	6.0	G	.08	073	9.0	C	.02
205	6.0	H	.06	074	9.0	D	.02
206	6.0	I	.06	075	9.0	E	.05
207	6.0	J	.08	076	9.0	F	.05
335	6.0	K	.06	077	9.0	G	.05
336	6.0	L	.06	214	9.0	H	.02
337	6.0	M	.06	215	9.0	I	.02
338	6.0	N	.06	216	9.0	J	.05
339	6.0	P	.08	356	9.0	K	.018
340	6.0	R	.08	357	9.0	L	.018
341	6.0	S	.08	358	9.0	M	.02
438	6.0	T	.06	359	9.0	N	.02
057	7.0	A	.04	360	9.0	P	.05
058	7.0	B	.04	361	9.0	R	.05
059	7.0	C	.04	362	9.0	S	.05
060	7.0	D	.04	441	9.0	T	.02
061	7.0	E	.07	078	10.0	A	.02
062	7.0	F	.07	079	10.0	B	.02
063	7.0	G	.07	080	10.0	C	.02
208	7.0	H	.04	081	10.0	D	.02
209	7.0	I	.04	082	10.0	E	.04
210	7.0	J	.07	083	10.0	F	.04
342	7.0	K	.04	084	10.0	G	.04
343	7.0	L	.04	217	10.0	H	.02
344	7.0	M	.04	218	10.0	I	.02
345	7.0	N	.04	219	10.0	J	.04
346	7.0	P	.07	363	10.0	K	.02
347	7.0	R	.07	364	10.0	L	.02

MIL-PRF-55629/2G

TABLE I. Circuit breaker dash numbers and applicable characteristics (configuration 1) - Continued.

Dash no.	Current rating (amperes)	Voltage frequency and tripping time delay code letter (see tables III, IV, V and VIII)	Resistance or impedance ohms (max.)	Dash no.	Current rating (amperes)	Voltage frequency and tripping time delay code letter (see tables III, IV, V and VIII)	Resistance or impedance ohms (max.)
365	10.0	M	.02	385	20.0	L	.007
366	10.0	N	.02	386	20.0	M	.007
367	10.0	P	.04	387	20.0	N	.007
368	10.0	R	.04	388	20.0	P	.01
369	10.0	S	.04	389	20.0	R	.01
442	10.0	T	.02	390	20.0	S	.01
085	12.5	A	.013	445	20.0	T	.007
086	12.5	B	.013	106	25.0	A	.006
087	12.5	C	.015	107	25.0	B	.006
088	12.5	D	.015	108	25.0	C	.006
089	12.5	E	.03	109	25.0	D	.006
090	12.5	F	.03	110	25.0	E	.007
091	12.5	G	.03	111	25.0	F	.007
220	12.5	H	.013	112	25.0	G	.007
221	12.5	I	.013	229	25.0	H	.006
222	12.5	J	.03	230	25.0	I	.006
370	12.5	K	.013	231	25.0	J	.007
371	12.5	L	.013	391	25.0	K	.006
372	12.5	M	.015	392	25.0	L	.006
373	12.5	N	.015	393	25.0	M	.006
374	12.5	P	.03	394	25.0	N	.006
375	12.5	R	.03	395	25.0	P	.007
376	12.5	S	.03	396	25.0	R	.007
443	12.5	T	.015	397	25.0	S	.007
092	15.0	A	.01	446	25.0	T	.006
093	15.0	B	.01	113	30.0	A	.005
094	15.0	C	.011	114	30.0	B	.005
095	15.0	D	.011	115	30.0	C	.005
096	15.0	E	.02	116	30.0	D	.005
097	15.0	F	.02	117	30.0	E	.006
098	15.0	G	.02	118	30.0	F	.006
223	15.0	H	.013	119	30.0	G	.006
224	15.0	I	.015	232	30.0	H	.005
225	15.0	J	.03	233	30.0	I	.005
377	15.0	K	.01	234	30.0	J	.006
378	15.0	L	.01	398	30.0	K	.005
379	15.0	M	.011	399	30.0	L	.005
380	15.0	N	.011	400	30.0	M	.005
381	15.0	P	.02	401	30.0	N	.005
382	15.0	R	.02	402	30.0	P	.006
383	15.0	S	.02	403	30.0	R	.006
444	15.0	T	.011	404	30.0	S	.006
099	20.0	A	.007	447	30.0	T	.005
100	20.0	B	.007	120	35.0	A	.004
101	20.0	C	.007	121	35.0	B	.004
102	20.0	D	.007	122	35.0	C	.004
103	20.0	E	.01	123	35.0	D	.004
104	20.0	F	.01	124	35.0	E	.005
105	20.0	G	.01	125	35.0	F	.005
226	20.0	H	.007	126	35.0	G	.005
227	20.0	I	.007	235	35.0	H	.004
228	20.0	J	.01	236	35.0	I	.004
384	20.0	K	.007	237	35.0	J	.005

MIL-PRF-55629/2G

TABLE I. Circuit breaker dash numbers and applicable characteristics (configuration 1) - Continued.

Dash no.	Current rating (amperes)	Voltage frequency and tripping time delay code letter (see tables III, IV, V and VIII)	Resistance or impedance ohms (max.)	Dash no.	Current rating (amperes)	Voltage frequency and tripping time delay code letter (see tables III, IV, V and VIII)	Resistance or impedance ohms (max.)
405	35.0	K	.004	416	40.0	P	.0052
406	35.0	L	.004	417	40.0	R	.0052
407	35.0	M	.004	418	40.0	S	.0052
408	35.0	N	.004	449	40.0	T	.0038
409	35.0	P	.005	127	50.0	A	.003
410	35.0	R	.005	128	50.0	B	.003
411	35.0	S	.005	129	50.0	C	.003
448	35.0	T	.004	130	50.0	D	.003
238	40.0	A	.0038	131	50.0	E	.004
239	40.0	B	.0038	132	50.0	F	.004
241	40.0	C	.0038	133	50.0	G	.004
242	40.0	D	.0038	248	50.0	H	.003
244	40.0	E	.0052	249	50.0	I	.003
245	40.0	F	.0052	250	50.0	J	.004
246	40.0	G	.0052	419	50.0	K	.003
240	40.0	H	.0038	420	50.0	L	.003
243	40.0	I	.0038	421	50.0	M	.003
247	40.0	J	.0052	422	50.0	N	.003
412	40.0	K	.0038	423	50.0	P	.004
413	40.0	L	.0038	424	50.0	R	.004
414	40.0	M	.0038	425	50.0	S	.004
415	40.0	N	.0038	450	50.0	T	.003

MIL-PRF-55629/2G

TABLE II. Circuit breaker dash numbers and applicable characteristics (configuration 2).

Dash no.	Current rating (amperes)	Voltage frequency and tripping time delay code letter (see tables VI, VII and VIII)	Resistance or impedance ohms (max.)	Dash no.	Current rating (amperes)	Voltage frequency and tripping time delay code letter (see tables VI, VII and VIII)	Resistance or impedance ohms (max.)
001L	0.2	A	52	269L	0.5	P	24
002L	0.2	B	52	270L	0.5	R	24
003L	0.2	C	32	271L	0.5	S	24
004L	0.2	D	34	428L	0.5	T	6
005L	0.2	E	88	150L	0.75	A	3
006L	0.2	F	88	151L	0.75	B	3
007L	0.2	G	88	153L	0.75	C	3
134L	0.2	H	52	154L	0.75	D	3
135L	0.2	I	34	156L	0.75	E	7
136L	0.2	J	88	157L	0.75	F	7
251L	0.2	K	52	158L	0.75	G	7
252L	0.2	L	52	152L	0.75	H	3
253L	0.2	M	32	155L	0.75	I	3
254L	0.2	N	34	159L	0.75	J	7
255L	0.2	P	88	272L	0.75	K	3
256L	0.2	R	88	273L	0.75	L	3
257L	0.2	S	88	274L	0.75	M	3
426L	0.2	T	34	275L	0.75	N	3
137L	0.25	A	26	276L	0.75	P	7
138L	0.25	B	26	277L	0.75	R	7
140L	0.25	C	23	278L	0.75	S	7
141L	0.25	D	23	429L	0.75	T	3
143L	0.25	E	43	015L	1.0	A	2
144L	0.25	F	43	016L	1.0	B	2
145L	0.25	G	43	017L	1.0	C	2
139L	0.25	H	26	018L	1.0	D	2
142L	0.25	I	23	019L	1.0	E	4
146L	0.25	J	43	020L	1.0	F	4
258L	0.25	K	26	021L	1.0	G	4
259L	0.25	L	26	160L	1.0	H	2
260L	0.25	M	23	161L	1.0	I	2
261L	0.25	N	23	162L	1.0	J	4
262L	0.25	P	43	279L	1.0	K	2
263L	0.25	R	43	280L	1.0	L	2
264L	0.25	S	43	281L	1.0	M	2
427L	0.25	T	23	282L	1.0	N	2
008L	0.5	A	7	283L	1.0	P	4
009L	0.5	B	7	284L	1.0	R	4
010L	0.5	C	6	285L	1.0	S	4
011L	0.5	D	6	430L	1.0	T	2
012L	0.5	E	24	163L	1.5	A	.9
013L	0.5	F	24	164L	1.5	B	.9
014L	0.5	G	24	166L	1.5	C	.9
147L	0.5	H	7	167L	1.5	D	.9
148L	0.5	I	6	169L	1.5	E	2
149L	0.5	J	24	170L	1.5	F	2
265L	0.5	K	7	171L	1.5	G	2
266L	0.5	L	7	165L	1.5	H	.9
267L	0.5	M	6	168L	1.5	I	.9
268L	0.5	N	6	172L	1.5	J	2

MIL-PRF-55629/2G

TABLE II. Circuit breaker dash numbers and applicable characteristics (configuration 2) - Continued.

Dash no.	Current rating (amperes)	Voltage frequency and tripping time delay code letter (see tables VI, VII and VIII)	Resistance or impedance ohms (max.)	Dash no.	Current rating (amperes)	Voltage frequency and tripping time delay code letter (see tables VI, VII and VIII)	Resistance or impedance ohms (max.)
286L	1.5	K	.9	035L	3.0	G	.5
287L	1.5	L	.9	186L	3.0	H	.3
288L	1.5	M	.9	187L	3.0	I	.3
289L	1.5	N	.9	188L	3.0	J	.5
290L	1.5	P	2	307L	3.0	K	.3
291L	1.5	R	2	308L	3.0	L	.3
292L	1.5	S	2	309L	3.0	M	.3
431L	2.0	T	.9	310L	3.0	N	.3
022L	2.0	A	.5	311L	3.0	P	.5
023L	2.0	B	.5	312L	3.0	R	.5
024L	2.0	C	.5	313L	3.0	S	.5
025L	2.0	D	.5	434L	3.0	T	.3
026L	2.0	E	.9	189L	3.5	A	.15
027L	2.0	F	.9	190L	3.5	B	.15
028L	2.0	G	.9	192L	3.5	C	.15
173L	2.0	H	.5	193L	3.5	D	.15
174L	2.0	I	.5	195L	3.5	E	.35
175L	2.0	J	.9	196L	3.5	F	.35
293L	2.0	K	.5	197L	3.5	G	.35
294L	2.0	L	.5	191L	3.5	H	.15
295L	2.0	M	.5	194L	3.5	I	.15
296L	2.0	N	.5	198L	3.5	J	.35
297L	2.0	P	.9	314L	3.5	K	.15
298L	2.0	R	.9	315L	3.5	L	.15
299L	2.0	S	.9	316L	3.5	M	.15
432L	2.0	T	.5	317L	3.5	N	.15
176L	2.5	A	.35	318L	3.5	P	.35
177L	2.5	B	.35	319L	3.5	R	.35
179L	2.5	C	.35	320L	3.5	S	.35
180L	2.5	D	.35	435L	3.5	T	.15
182L	2.5	E	.6	036L	4.0	A	.1
183L	2.5	F	.6	037L	4.0	B	.1
184L	2.5	G	.6	038L	4.0	C	.1
178L	2.5	H	.35	039L	4.0	D	.1
181L	2.5	I	.35	040L	4.0	E	.3
185L	2.5	J	.6	041L	4.0	F	.3
300L	2.5	K	.35	042L	4.0	G	.3
301L	2.5	L	.35	199L	4.0	H	.1
302L	2.5	M	.35	200L	4.0	I	.1
303L	2.5	N	.35	201L	4.0	J	.3
304L	2.5	P	.6	321L	4.0	K	.1
305L	2.5	R	.6	322L	4.0	L	.1
306L	2.5	S	.6	323L	4.0	M	.1
433L	2.5	T	.35	324L	4.0	N	.1
029L	3.0	A	.3	325L	4.0	P	.3
030L	3.0	B	.3	326L	4.0	R	.3
031L	3.0	C	.3	327L	4.0	S	.3
032L	3.0	D	.3	436L	4.0	T	.1
033L	3.0	E	.5	043L	5.0	A	.08
034L	3.0	F	.5	044L	5.0	B	.08

MIL-PRF-55629/2G

TABLE II. Circuit breaker dash numbers and applicable characteristics (configuration 2) - Continued.

Dash no.	Current rating (amperes)	Voltage frequency and tripping time delay code letter (see tables VI, VII and VIII)	Resistance or impedance ohms (max.)	Dash no.	Current rating (amperes)	Voltage frequency and tripping time delay code letter (see tables VI, VII and VIII)	Resistance or impedance ohms (max.)
045L	5.0	C	.08	348L	7.0	S	.078
046L	5.0	D	.08	449L	7.0	T	.04
047L	5.0	E	.15	064L	8.0	A	.03
048L	5.0	F	.15	065L	8.0	B	.03
049L	5.0	G	.15	066L	8.0	C	.03
202L	5.0	H	.08	067L	8.0	D	.03
203L	5.0	I	.08	068L	8.0	E	.063
204L	5.0	J	.15	069L	8.0	F	.063
328L	5.0	K	.08	070L	8.0	G	.063
329L	5.0	L	.08	211L	8.0	H	.03
330L	5.0	M	.08	212L	8.0	I	.03
331L	5.0	N	.08	213L	8.0	J	.063
332L	5.0	P	.15	349L	8.0	K	.03
333L	5.0	R	.15	350L	8.0	L	.03
334L	5.0	S	.15	351L	8.0	M	.03
437L	5.0	T	.08	352L	8.0	N	.03
050L	6.0	A	.06	353L	8.0	P	.063
051L	6.0	B	.06	354L	8.0	R	.063
052L	6.0	C	.06	355L	8.0	S	.063
053L	6.0	D	.06	440L	8.0	T	.03
054L	6.0	E	.104	071L	9.0	A	.028
055L	6.0	F	.104	072L	9.0	B	.028
056L	6.0	G	.104	073L	9.0	C	.025
205L	6.0	H	.06	074L	9.0	D	.025
206L	6.0	I	.06	075L	9.0	E	.05
207L	6.0	J	.104	076L	9.0	F	.05
335L	6.0	K	.06	077L	9.0	G	.05
336L	6.0	L	.06	214L	9.0	H	.028
337L	6.0	M	.06	215L	9.0	I	.025
338L	6.0	N	.06	216L	9.0	J	.05
339L	6.0	P	.104	356L	9.0	K	.028
340L	6.0	R	.104	357L	9.0	L	.028
341L	6.0	S	.104	358L	9.0	M	.025
438L	6.0	T	.06	359L	9.0	N	.025
057L	7.0	A	.041	360L	9.0	P	.05
058L	7.0	B	.041	361L	9.0	R	.05
059L	7.0	C	.04	362L	9.0	S	.05
060L	7.0	D	.04	441L	9.0	T	.025
061L	7.0	E	.078	078L	10.0	A	.023
062L	7.0	F	.078	079L	10.0	B	.023
063L	7.0	G	.078	080L	10.0	C	.02
208L	7.0	H	.041	081L	10.0	D	.02
209L	7.0	I	.04	082L	10.0	E	.04
210L	7.0	J	.078	083L	10.0	F	.04
342L	7.0	K	.041	084L	10.0	G	.04
343L	7.0	L	.041	217L	10.0	H	.023
344L	7.0	M	.04	218L	10.0	I	.02
345L	7.0	N	.04	219L	10.0	J	.043
346L	7.0	P	.078	363L	10.0	K	.023
347L	7.0	R	.078	364L	10.0	L	.023

MIL-PRF-55629/2G

TABLE II. Circuit breaker dash numbers and applicable characteristics (configuration 2) - Continued.

Dash no.	Current rating (amperes)	Voltage frequency and tripping time delay code letter (see tables VI, VII and VIII)	Resistance or impedance ohms (max.)	Dash no.	Current rating (amperes)	Voltage frequency and tripping time delay code letter (see tables VI, VII and VIII)	Resistance or impedance ohms (max.)
365L	10.0	M	.02	385L	20.0	L	.008
366L	10.0	N	.02	386L	20.0	M	.008
367L	10.0	P	.04	387L	20.0	N	.008
368L	10.0	R	.04	388L	20.0	P	.013
369L	10.0	S	.04	389L	20.0	R	.013
442L	10.0	T	.02	390L	20.0	S	.013
085L	12.5	A	.015	445L	20.0	T	.008
086L	12.5	B	.015	106L	25.0	A	.006
087L	12.5	C	.015	107L	25.0	B	.006
088L	12.5	D	.015	108L	25.0	C	.006
089L	12.5	E	.03	109L	25.0	D	.006
090L	12.5	F	.03	110L	25.0	E	.011
091L	12.5	G	.03	111L	25.0	F	.011
220L	12.5	H	.015	112L	25.0	G	.011
221L	12.5	I	.013	229L	25.0	H	.006
222L	12.5	J	.03	230L	25.0	I	.006
370L	12.5	K	.015	231L	25.0	J	.011
371L	12.5	L	.015	391L	25.0	K	.006
372L	12.5	M	.015	392L	25.0	L	.006
373L	12.5	N	.015	393L	25.0	M	.006
374L	12.5	P	.03	394L	25.0	N	.006
375L	12.5	R	.03	395L	25.0	P	.011
376L	12.5	S	.03	396L	25.0	R	.011
443L	12.5	T	.015	397L	25.0	S	.011
092L	15.0	A	.01	446L	25.0	T	.006
093L	15.0	B	.01	113L	30.0	A	.005
094L	15.0	C	.011	114L	30.0	B	.005
095L	15.0	D	.011	115L	30.0	C	.006
096L	15.0	E	.02	116L	30.0	D	.006
097L	15.0	F	.02	117L	30.0	E	.009
098L	15.0	G	.02	118L	30.0	F	.009
223L	15.0	H	.013	119L	30.0	G	.009
224L	15.0	I	.015	232L	30.0	H	.005
225L	15.0	J	.03	233L	30.0	I	.006
377L	15.0	K	.01	234L	30.0	J	.009
378L	15.0	L	.01	398L	30.0	K	.005
379L	15.0	M	.011	399L	30.0	L	.005
380L	15.0	N	.011	400L	30.0	M	.006
381L	15.0	P	.02	401L	30.0	N	.006
382L	15.0	R	.02	402L	30.0	P	.009
383L	15.0	S	.02	403L	30.0	R	.009
444L	15.0	T	.011	404L	30.0	S	.009
099L	20.0	A	.008	447L	30.0	T	.006
100L	20.0	B	.008	120L	35.0	A	.004
101L	20.0	C	.008	121L	35.0	B	.004
102L	20.0	D	.008	122L	35.0	C	.005
103L	20.0	E	.013	123L	35.0	D	.005
104L	20.0	F	.013	124L	35.0	E	.006
105L	20.0	G	.013	125L	35.0	F	.006
226L	20.0	H	.008	126L	35.0	G	.006
227L	20.0	I	.008	235L	35.0	H	.004
228L	20.0	J	.013	236L	35.0	I	.005
384L	20.0	K	.008	237L	35.0	J	.006

MIL-PRF-55629/2G

TABLE II. Circuit breaker dash numbers and applicable characteristics (configuration 2) - Continued.

Dash no.	Current rating (amperes)	Voltage frequency and tripping time delay code letter (see tables VI, VII and VIII)	Resistance or impedance ohms (max.)	Dash no.	Current rating (amperes)	Voltage frequency and tripping time delay code letter (see tables VI, VII and VIII)	Resistance or impedance ohms (max.)
405L	35.0	K	.004	416L	40.0	P	.0052
406L	35.0	L	.004	417L	40.0	R	.0052
407L	35.0	M	.005	418L	40.0	S	.0052
408L	35.0	N	.005	449L	40.0	T	.0045
409L	35.0	P	.006	127L	50.0	A	.004
410L	35.0	R	.006	128L	50.0	B	.004
411L	35.0	S	.006	129L	50.0	C	.004
448L	35.0	T	.005	130L	50.0	D	.003
238L	40.0	A	.0038	131L	50.0	E	.004
239L	40.0	B	.0038	132L	50.0	F	.004
241L	40.0	C	.0045	133L	50.0	G	.004
242L	40.0	D	.0045	248L	50.0	H	.003
244L	40.0	E	.0052	249L	50.0	I	.003
245L	40.0	F	.0052	250L	50.0	J	.004
246L	40.0	G	.0052	419L	50.0	K	.004
240L	40.0	H	.0038	420L	50.0	L	.004
243L	40.0	I	.0045	421L	50.0	M	.004
247L	40.0	J	.0052	422L	50.0	N	.003
412L	40.0	K	.0038	423L	50.0	P	.004
413L	40.0	L	.0038	424L	50.0	R	.004
414L	40.0	M	.0045	425L	50.0	S	.004
415L	40.0	N	.0045	450L	50.0	T	.003

TABLE III. Tripping-time delay (configuration 1). 1/ 2/

Time delay percent rated current	Tripping-time delay at 25°C ±2°C (tripping time in seconds)													
	50 V dc				240 V ac, 60 Hz				240 V ac, 400 Hz					
	A		B		C		D		E		F		G	
	Max	Min	Max	Min	Max	Min	Max	Min	Max	Min	Max	Min	Max	Min
100	no trip one hour		no trip one hour		no trip one hour		no trip one hour		no trip one hour		no trip one hour		no trip one hour	
125	70	7	7	.5	120	10	17	.7	N/A	N/A	N/A	N/A	N/A	N/A
150	N/A	N/A	N/A	N/A	N/A	N/A	N/A	N/A	60	5	5.8	.50	400	40
200	8	.6	1.4	.13	20	2.2	1.6	.13	20	2.1	1.9	.15	150	9.5
400	1.5	.15	.25	.031	2.3	.3	.25	.03	3.2	.4	.19	.02	19	1.9
600	.05	Inst	.12	Inst	.75	Inst	.13	Inst	.19	Inst	.08	Inst	1.6	Inst
800	.051	Inst	.051	Inst	.16	Inst	.07	Inst	.06	Inst	.05	Inst	.06	Inst
1,000	.026	Inst	.026	Inst	.04	Inst	.04	Inst	.045	Inst	.036	Inst	.043	Inst

See footnotes at end of table VIII.

TABLE IV. Tripping-time, high-inrush design (configuration 1). 1/ 3/

Time delay percent rated current	Tripping-time delay at 25°C ±2°C (tripping time in seconds)															
	50 V dc				240 V ac, 60 Hz						240 V ac, 400 Hz					
	K		L		M		N		T		P		R		S	
	Max	Min	Max	Min	Max	Min	Max	Min	Max	Min	Max	Min	Max	Min	Max	Min
100	no trip one hour		no trip one hour		no trip one hour		no trip one hour		no trip one hour		no trip one hour		no trip one hour		no trip one hour	
125	100	10	12	.5	120	10	18	1	700	50	N/A	N/A	N/A	N/A	N/A	N/A
150	N/A	N/A	N/A	N/A	N/A	N/A	N/A	N/A	350	32	60	6	5.8	.6	500	60
200	20	2.5	1.5	.13	20	3	1.6	.16	70	10	20	2.1	2	.2	160	20
400	2	.36	.29	.031	2.3	.3	.3	.04	15	1.5	4	.4	.35	.035	19	2
600	1	.13	.15	Inst	1	.13	.17	Inst	7	.7	.6	Inst	.125	Inst	3.5	.250
800	.6	Inst	.06	Inst	.6	Inst	.09	Inst	3	.1	.06	Inst	.05	Inst	.5	.025
1,000	.29	Inst	.05	Inst	.29	Inst	.043	Inst	2	.01	.045	Inst	.036	Inst	.043	Inst
1,800 4/	no trip		no trip		no trip		no trip		no trip		no trip		no trip		no trip	

See footnotes at end of table VIII.

TABLE V. Tripping-time, standard delay and high-inrush design (configuration 1). 1/ 2/ 3/

Time delay percent rated current	Tripping-time delay at high and low temperature °C (tripping time in seconds) 5/															
	50 V dc				240 V ac, 60 Hz						240 V ac, 400 Hz					
	A and K		B and L		C and M		D and N		T		E and P		F and R		G and S	
	-40° Max	+85° Min	-40° Max	+85° Min	-40° Max	+85° Min	-40° Max	+85° Min	-40° Max	+85° Min	-40° Max	+85° Min	-40° Max	+85° Min	-40° Max	+85° Min
100	no trip one hour		no trip one hour		no trip one hour		no trip one hour		no trip one hour		no trip one hour		no trip one hour		no trip one hour	
125	500	5	100	.1	500	1	100	.1	8000	25	N/A	N/A	N/A	N/A	N/A	N/A
150	N/A	N/A	N/A	N/A	N/A	N/A	N/A	N/A	900	12	500	.5	100	.1	1500	5
200	100	.1	10	0.05	100	.05	10	.05	500	5	100	.1	10	.5	500	.5
400	20	Inst	3	Inst	20	Inst	3	Inst	100	.8	20	Inst	3	Inst	100	Inst
600	5	Inst	1	Inst	5	Inst	1	Inst	40	.1	6	Inst	1	Inst	5	Inst
800	2	Inst	.5	Inst	.5	Inst	.5	Inst	10	.05	.5	Inst	.5	Inst	.5	Inst
1,000	N/A	N/A	N/A	N/A	N/A	N/A	N/A	N/A	3	.01	N/A	N/A	N/A	N/A	N/A	N/A

See footnotes at end of table VIII.

TABLE VI. Tripping-time, standard delay and high-inrush design (configuration 2). 1/ 2/ 3/

Time delay percent rated current	Tripping-time delay at 25°C ±2°C (tripping time in seconds)															
	50 V dc				240 V ac, 60 Hz						240 V ac, 400 Hz					
	A and K		B and L		C and M		D and N		T		E and P		F and R		G and S	
	Max	Min	Max	Min	Max	Min	Max	Min	Max	Min	Max	Min	Max	Min	Max	Min
100	no trip one hour		no trip one hour		no trip one hour		no trip one hour		no trip one hour		no trip one hour		no trip one hour		no trip one hour	
125	60	7	6.5	0.5	120	10	12	0.7	700	50	N/A	N/A	N/A	N/A	N/A	N/A
150	N/A	N/A	N/A	N/A	N/A	N/A	N/A	N/A	400	30	70	5	8	0.5	400	40
200	10	.6	1.2	0.13	20	2.2	3	0.13	150	10	25	2.1	1.9	0.15	150	9.5
400	2	.15	0.5	0.031	3	0.3	1	0.03	20	1.5	5	0.4	0.4	0.02	19	1.9
600	1	Inst	0.25	Inst	2	Inst	0.3	Inst	10	0.4	2.4	Inst	0.25	Inst	7	Inst
800	0.5	Inst	0.1	Inst	0.8	Inst	0.15	Inst	8	Inst	1	Inst	0.1	Inst	0.4	Inst
1,000	0.1	Inst	Inst	Inst	0.25	Inst	0.1	Inst	6	Inst	0.1	Inst	0.05	Inst	0.043	Inst
1,800 4/	no trip		no trip		no trip		no trip		no trip		no trip		no trip		no trip	

See footnotes at end of table VIII.

TABLE VII. Tripping-time, high-low temperature standard delay and high-inrush delay (configuration 2). 1/ 2/ 3/

Time delay percent rated current	Tripping-time delay at high and low temperature °C (tripping time in seconds) 5/															
	50 V dc				240 V ac, 60 Hz						240 V ac, 400 Hz					
	A and K		B and L		C and M		D and N		T		E and P		F and R		G and S	
	-40° Max	+85° Min	-40° Max	+85° Min	-40° Max	+85° Min	-40° Max	+85° Min	-40° Max	+85° Min	-40° Max	+85° Min	-40° Max	+85° Min	-40° Max	+85° Min
100	no trip one hour		no trip one hour		no trip one hour		no trip one hour		no trip one hour		no trip one hour		no trip one hour		no trip one hour	
125	500	5	100	0.1	700	1	100	0.1	8000	25	N/A	N/A	N/A	N/A	N/A	N/A
150	N/A	N/A	N/A	N/A	N/A	N/A	N/A	N/A	1600	12	600	0.5	100	0.1	1500	5
200	100	.1	10	0.05	160	0.05	10	0.05	1200	5	130	0.1	10	0.05	500	0.5
400	20	Inst	3	Inst	26	Inst	3	Inst	130	0.8	32	Inst	3	Inst	100	Inst
600	5	Inst	1	Inst	13	Inst	1	Inst	60	0.055	26	Inst	1	Inst	24	Inst
800	2	Inst	0.5	Inst	2.8	Inst	0.5	Inst	28	Inst	8.4	Inst	0.5	Inst	3	Inst
1,000	N/A	N/A	N/A	N/A	N/A	N/A	N/A	N/A	10	Inst	N/A	N/A	N/A	N/A	N/A	N/A

See footnotes at end of table VIII.

20

MIL-PRF-55629/2G

MIL-PRF-55629/2G

TABLE VIII. Tripping-time, high-inrush nondelay (configuration 1 and 2). 1/ 2/

Time delay percent rated current	Tripping-time delay at -40°C ±2°C, +25°C ±2°C, and +85°C ±2°C (tripping time in seconds)					
	50 V dc		240 V ac, 60Hz		240 V ac, 400 Hz	
	H (nondelay)		I (nondelay)		J (nondelay)	
	Max	Min	Max	Min	Max	Min
100	no trip one hour		no trip one hour		no trip one hour	
125	0.15	Inst	0.15	Inst	---	---
150	---	---	---	---	0.150	Inst
200	0.07	Inst	0.05	Inst	0.070	Inst
400	0.032	Inst	0.022	Inst	0.032	Inst
600	0.02	Inst	0.017	Inst	0.020	Inst
800	0.02	Inst	0.017	Inst	0.020	Inst

- 1/ Circuit breakers shall not trip at 100 percent rated current. Characteristics A, B, C, D, H, I, K, L, M, and N must trip at 125 percent rated current; E, F, G, J, P, R, and S at 150 percent. Any characteristic may trip between 100 percent and the must-trip value. Instantaneous (Inst) is defined as less than 15 milliseconds.
- 2/ Voltage, frequency, and tripping-time delay codes A, B, C, D, E, F, G, H, I, and J are standard delays without the high-inrush feature.
- 3/ Voltage, frequency, and time delay codes K, L, M, N, P, R, S, and T incorporate the high-inrush or transient suppression feature.
- 4/ High-inrush test shall be performed using one alternation which has a peak value of 1,800 percent of rated current. 400 Hz and dc delays are subjected to a 400 Hz waveform, 60 Hz delays shall be subjected to a 60 Hz waveform.
- 5/ High and low test temperature tolerances are ±2°C.

MIL-PRF-55629/2G

TABLE IX. Supersession and substitution data.

Circuit breakers covered by this specification sheet are substitutable for the manufacturer's PINs as shown below. This information in no way implies that the manufacturer's PIN is substitutable for the military PIN.

Superseding military PIN	Superseded manufacturers PIN	
M55629/2-XXX	CAGE 81541	CAGE 74193
	Type APL-1 UPL-1 IEL-1	Type AM1
	The complete PIN consists of the type (above) plus identification codes for comparable internal connections, voltage, frequency, time delay and current rating.	

Reference documents. In addition to [MIL-PRF-55629](#), this document references the following:

- [ASTM-B121/B121M](#)
- [ASTM-B139/B139M](#)
- [ASTM-B545](#)
- [NASM35333](#)
- [MS35335](#)
- [NASM35338](#)

| The margins of this specification are marked with vertical lines to indicate where changes from the previous issue were made. This was done as a convenience only and the Government assumes no liability whatsoever for any inaccuracies in these notations. Bidders and contractors are cautioned to evaluate the requirements of this document based on the entire content irrespective of the marginal notations and relationship to the last previous issue.

Custodians:
 Army - CR
 Navy - EC
 Air Force - 85
 DLA - CC

Preparing activity:
 Army - CR
 Agent:
 DLA - CC

| Review activities:
 Army - AV, CR4
 Navy - AS, MC, OS
 Air Force - 19, 99

(Project 5925-2010-002)

NOTE: The activities listed above were interested in this document as of the date of this document. Since organizations and responsibilities can change, you should verify the currency of the information above using the ASSIST Online database at <https://assist.daps.dla.mil>.